

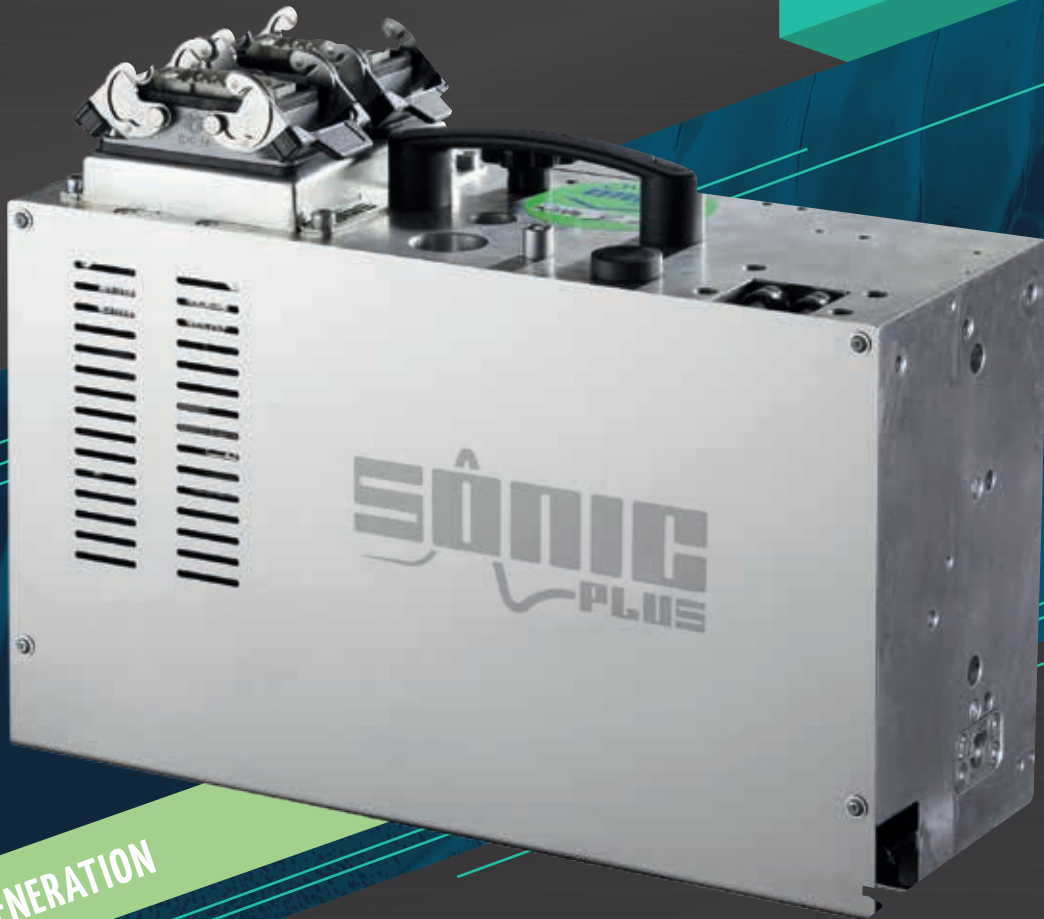

STRAPPING HEADS



NEW GENERATION

SONIC PLUS

Ultra Sonic Sealing Technology



Applications



Paper



Cardboard



Plastic/Cans



Glass

SONIC Plus

SONIC_EN

The SONIC Plus model strapping head, with its innovative Ultra Sonic Sealing Technology, represents the state-of-the-art in the field of strapping heads.

Thanks to its compact size and reduced weight, the new ultrasonic head is easy to move for maintenance and replacement. No waste of time during exchange or maintenance.

Advantages

- Innovative Ultra Sonic Sealing Technology
- High Performance
- Very compact
- Very easy to handle
- Can be exchanged (without tools) for maintenance in less than 60 secs.
- Reliable seals on PP or PET strap

Technical data

Strap	
Type of strap	Polyester (PET) Polypropylene (PP)
Width	9 ÷ 12 mm
Thickness	0,4 ÷ 0,6 mm
Tensioning	Up to 1500 N with manual adjustment

Max feeding and recovery speed	5,5 m/s
Utilization temperature	-10° ÷ 50° C
Noise level	< 70 dB
Option	Automatic strap refeeding device

ONLY 25KG



Dimensions

- L 400 mm
- H 240 mm
- W 160 mm
- Weight 25 kg

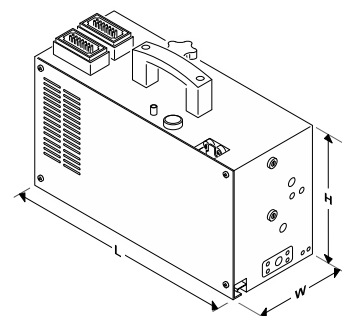

Industrial quick connectors for fast replacement.



Installation on a vertical strapping machine with press (cardboard application)



Officina Meccanica Sestese S.p.A.

Via Borgomanero, 44 - 28040 Paruzzaro (NO)

Tel. +39 0322 541411 Fax +39 0322 53157

www.omsspa.com

info@omsspa.com

As a part of our policy of continuous improvement, we reserve the right to alter design and specifications without prior notice. This brochure is for descriptive purpose only. Some of the items pictured in this brochure are optional and not standard equipment.